

FORCED AIR HEATERS DEFROSTER C450 (AC)

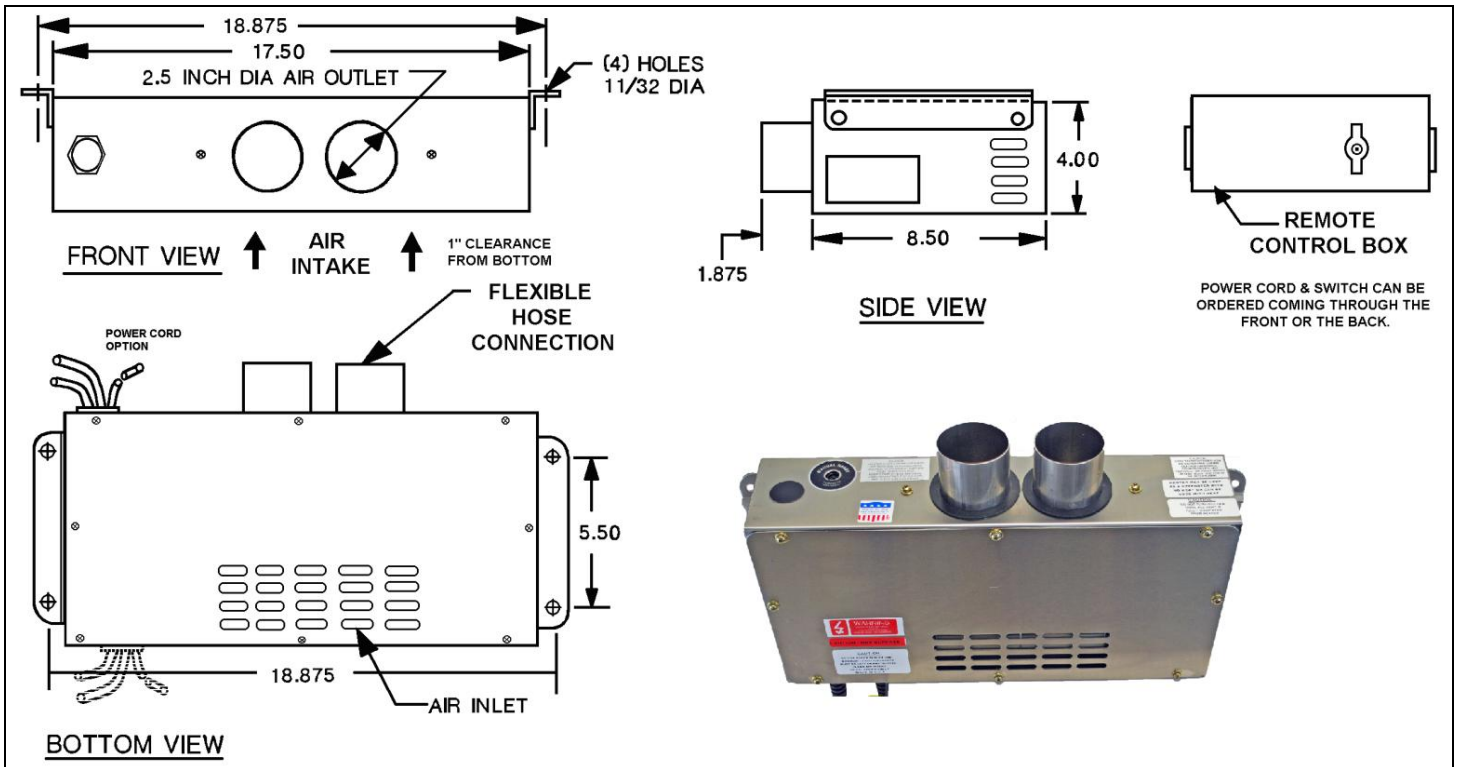

HOW TO ORDER: C450 - 1 1.5 - 1 NM

Basic Model
Voltage 120
Wattage 1.5KW
Phase: 1
Non-Magnetic
Stainless Steel (NM)

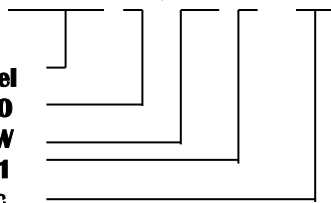

HEATER INCLUDES: Auto & Manual Hi-Limit, Blower
Mounting Brackets
Fan/Off/Heat Switch with 6 foot cord.

Unit can be supplied with Remote
Box (SP) with Fan/Off/Heat Switch
Operates up to 3 Defrosters

Note: When ordering, specify exact
parameters from below.

Heater Range: Voltage 110-120 VAC
Wattage 0.1-1.5 KW
Weight 20lbs
*Also available in 220V, 1PH

Construction: 18 GA Stainless Steel Cabinet
2 Individual Stainless Steel
Heating Elements with Fins Furnace Brazed.
Heating Elements Hermetically Sealed.
***Heater listed to UL-2021 (ETL)

Customer can specify lead length for
power cord (standard 6 feet).
Heater can be used in Fan position for air only.

Unit is manufactured to USCG, IEEE 45
and ANSI/UL-2021 specifications.



www.ValadElectric.com

Phone: (888)509-4927

Email: info@valadelectric.com

FORCED AIR HEATERS DEFROSTER C450 (DC)

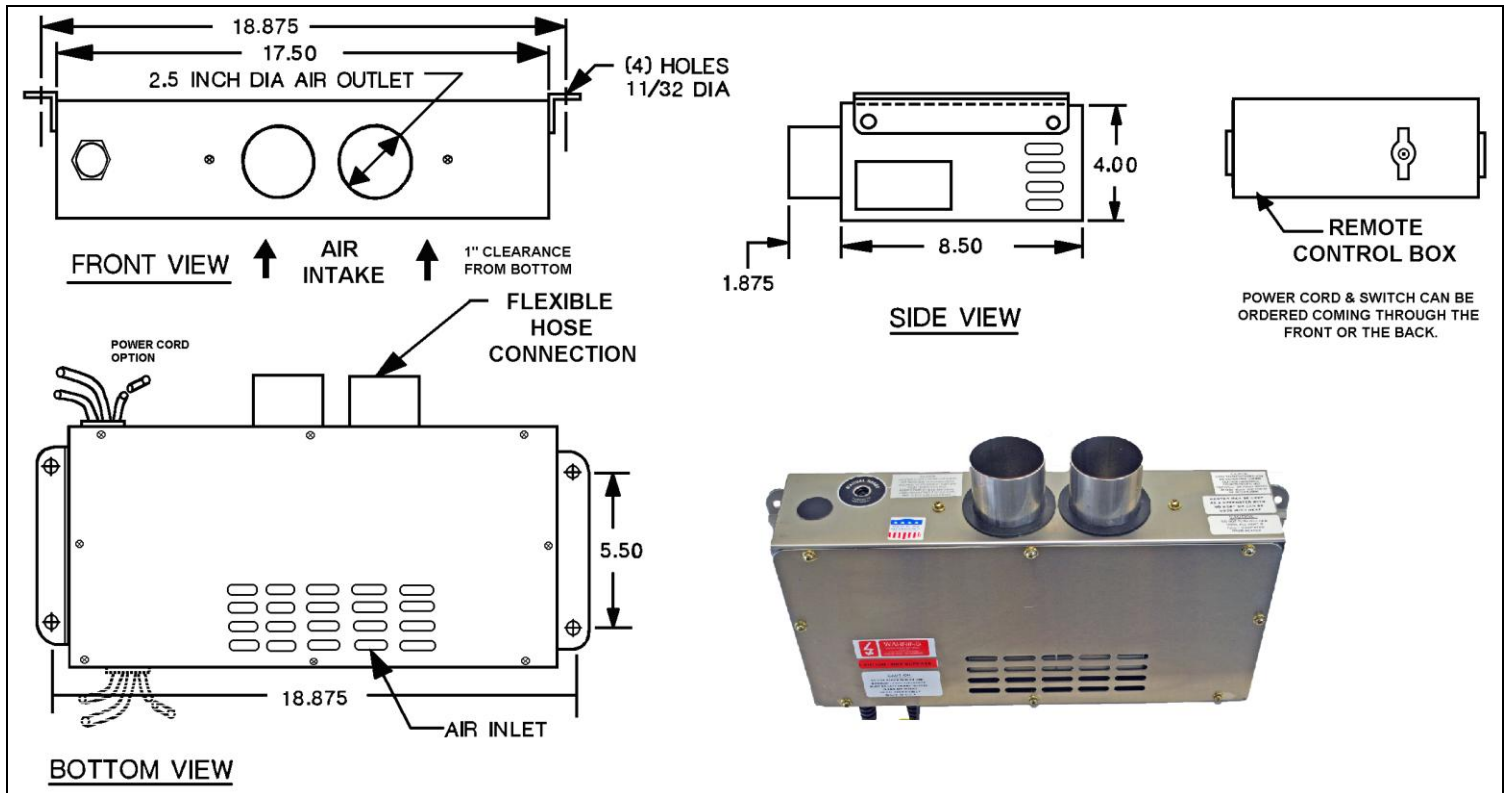

HOW TO ORDER: C450 - 72-1.5 DC -NM

Basic Model
Voltage 72
Wattage 1.5KW
DC Current
Non-Magnetic
Stainless Steel (NM)

HEATER INCLUDES: Fan/Off/Heat Switch with 72" cord ;for remote mounting, Auto Hi-limit Contactor, Power Terminal Block, Blower and Mounting Brackets.
Options:
 Specify cord length
 Power Terminal Block or Leads
 Control Terminal Block or Leads

Note: When ordering, specify exact parameters from below.

Heater Range: Voltage 12-250 VDC
 Wattage 0.1-1.5 KW
 Weight 20lbs

Unit is manufactured to IEEE 45 and UL guidelines.

Construction: 18 GA Stainless Steel Cabinet
 2 Individual Stainless Steel Heating Elements with Fins Furnace Brazed.

Heater can be used in Fan position for air only.



www.ValadElectric.com

Phone: (888)509-4927

Email: info@valadelectric.com