

FORCED AIR HEATERS

C400 (AC)

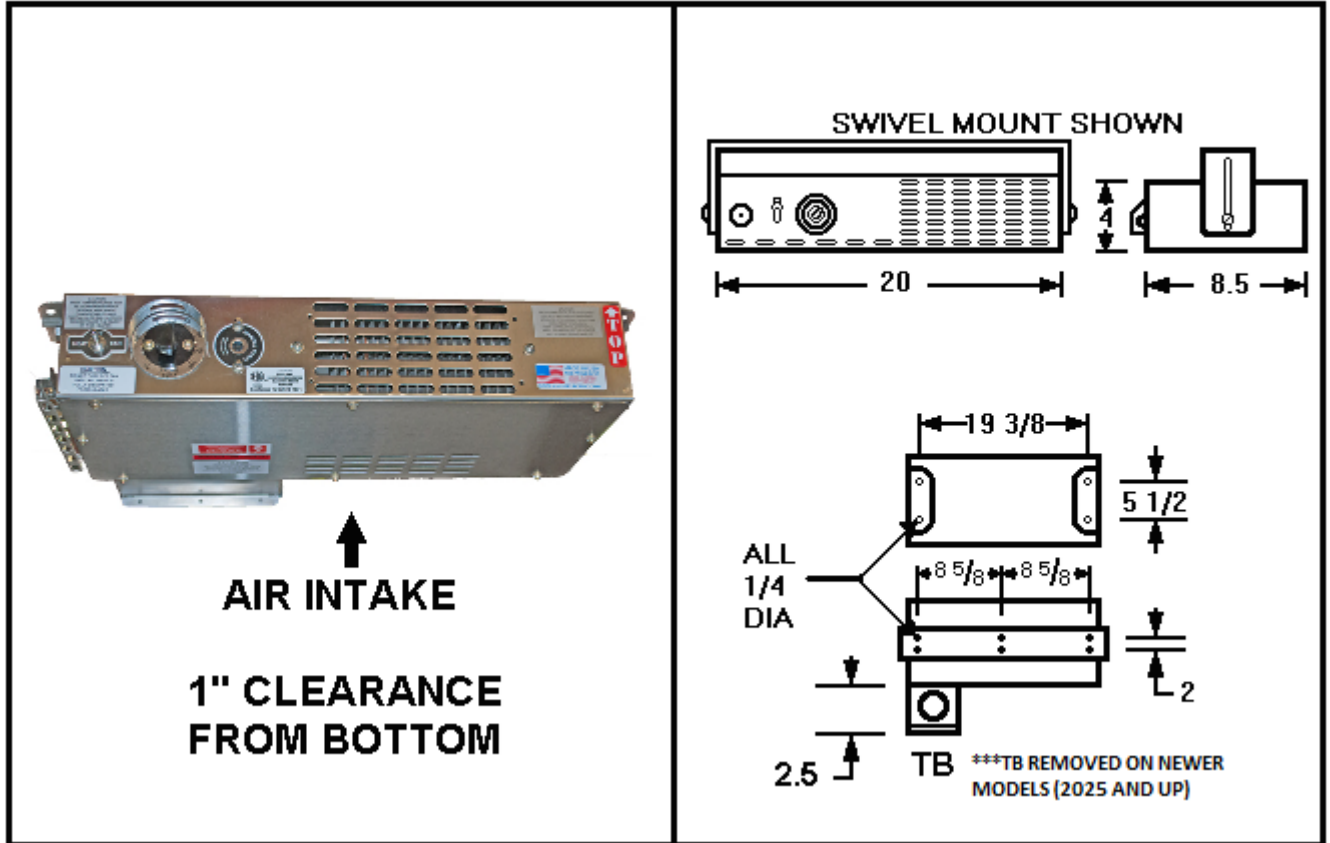

HOW TO ORDER:

	C400	- 1	1.5	- 1	NM
Basic Model	_____				
Voltage	_____				
Wattage 1.5KW	_____				
Phase (1)	_____				
Stainless Steel(NM)	_____				

- HEATER INCLUDES:**
- Fan/Off/Heat switch
 - Operating thermostat (40-100 Deg. F)
 - Manual & Auto thermal cut-out
 - Marine Terminal Box
 - Ceiling Bracket (swivel or fixed (standard))

- Construction:**
- 18 GA Stainless Steel
 - 2 Individual Stainless Steel Heating Elements with Fins Furnace Brazed
 - Heating Elements Hermetically Sealed
 - Heater Listed to UL-2021 (ETL)

Note: When ordering, specify exact measurements needed from the ranges indicated below.

Heater Range:

Voltage	110-120 VAC
Wattage	0.1-1.5 KW
Phase	1
Cycle	60Hz
Weight	15 lbs.

Unit is in accordance with USCG, IEEE 45 and ETL/ANSI/UL-2021 Guidelines.



www.ValadElectric.com

Phone: (888)509-4927

Email: info@valadelectric.com

FORCED AIR HEATERS

C400 (DC)

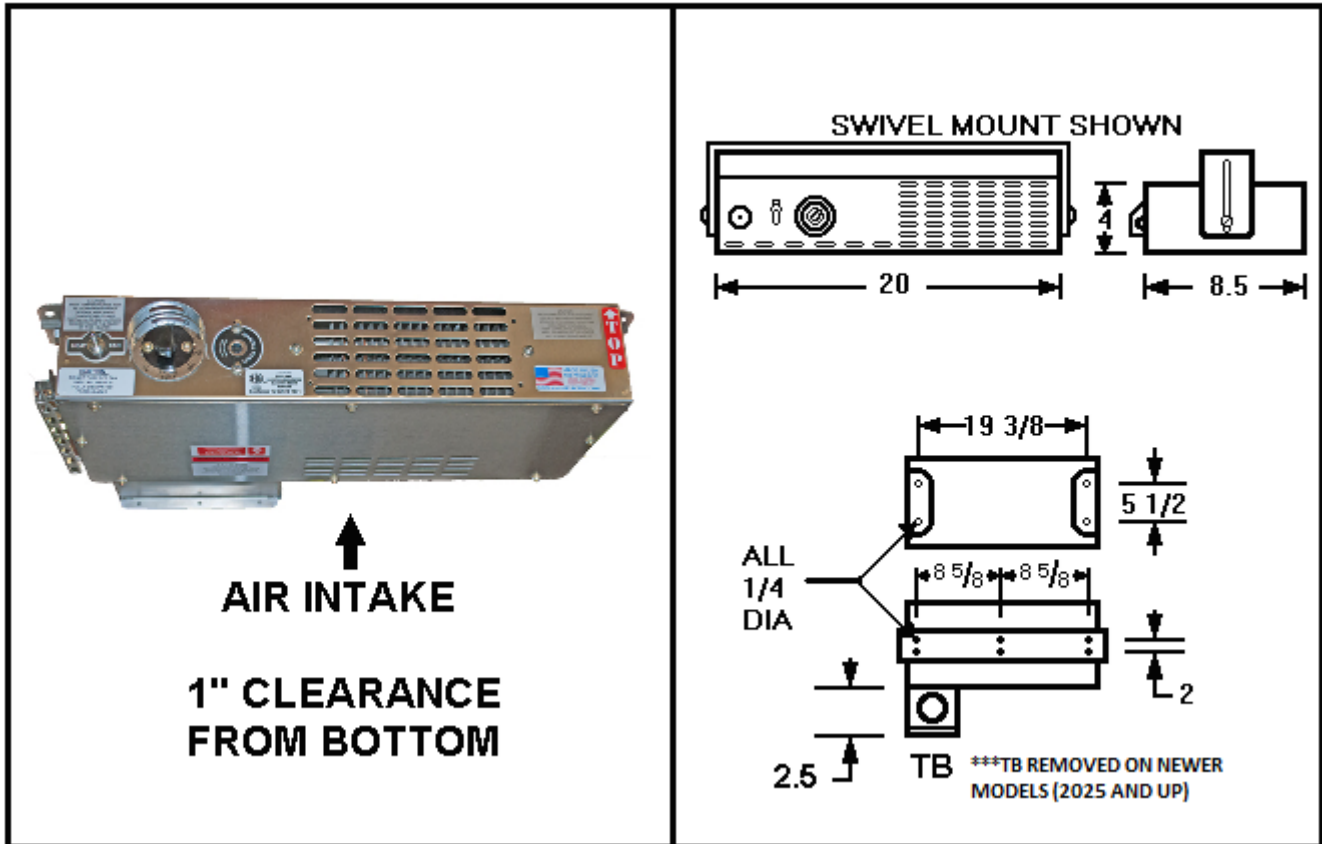

HOW TO ORDER: **C400 - 12 - 0.5 DC - NM**

Basic Model _____
Voltage 12VDC _____
Wattage 0.5KW _____
Phase (DC) _____
Stainless Steel(NM) _____

HEATER INCLUDES: Fan/Off/Heat Switch
 Operating thermostat
 Manual & Auto thermal cut-out
 Marine Terminal Box
 Contactor
 Ceiling Bracket (swivel or fixed (standard))

Note: When ordering, specify exact measurements needed from the ranges indicated below.

Heater Range: Voltage 12-72 VDC
 Wattage 0.1-1.5 KW
 Phase 1PH
 Weight 15 lbs.

Construction: 18 GA stainless steel only
 2 Individual Stainless Steel Heating Elements with Fins Furnace Brazed

Unit is manufactured to follow IEEE 45 and ANSI/UL-2021 Guidelines.



www.ValadElectric.com
 Phone: (888)509-4927
 Email: info@valadelectric.com