

FORCED AIR HEATERS

215 Space Heater

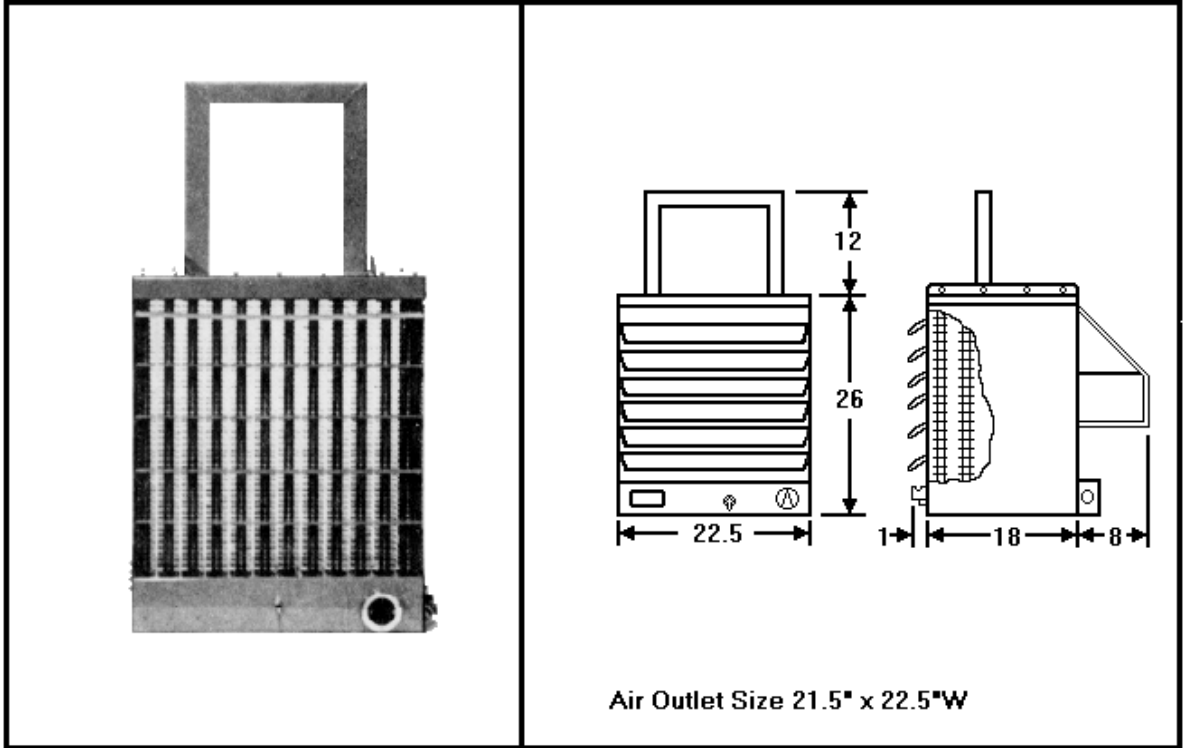

HOW TO ORDER: **215** **4** **40.0** **- 3** **NM**

Basic Model ————
Voltage 440 ————
Wattage 40.0KW ————
Phase (3) ————
Stainless Steel (NM) ————

HEATER

- INCLUDES:**
- Operating thermostat (40-100Deg F) (2 stage)
 - Auto and Manual Hi-limit Thermostat
 - Fused Transformer (when required)
 - Contactor
 - 12 in. Ceiling/Bulkhead Bracket
 - Terminal Box
 - Fan, motor, and louvers
 - Fan/Off/Heat Switch
 - ***Remote Thermostat Optional (24VAC)
 - ***Power Disconnect Switch Optional

Note: When ordering, specify exact measurements needed from the ranges indicated below.

Heater Range:

Voltage	440-480 VAC
Wattage	25.5-40.0 KW
Phase	3
Cycle	60Hz
Weight	200 lbs.

- Construction:**
- 14 GA 304 Stainless Steel (SST)
 - 30 Individual Heating Elements
 - SST Heating Elements
 - Fins Furnace Brazed to Sheath
 - Heating Elements Hermetically Sealed
 - ***Sway Bar Optional
 - ***Heater listed to UL-2021 (ETL)

Unit is manufactured I/A/W USCG, IEEE 45 and ETL/ANSI/UL-2021 specifications.



www.ValadElectric.com

Phone: (888)509-4927

Email: info@valadelectric.com