

FORCED AIR HEATERS

212 Space Heater

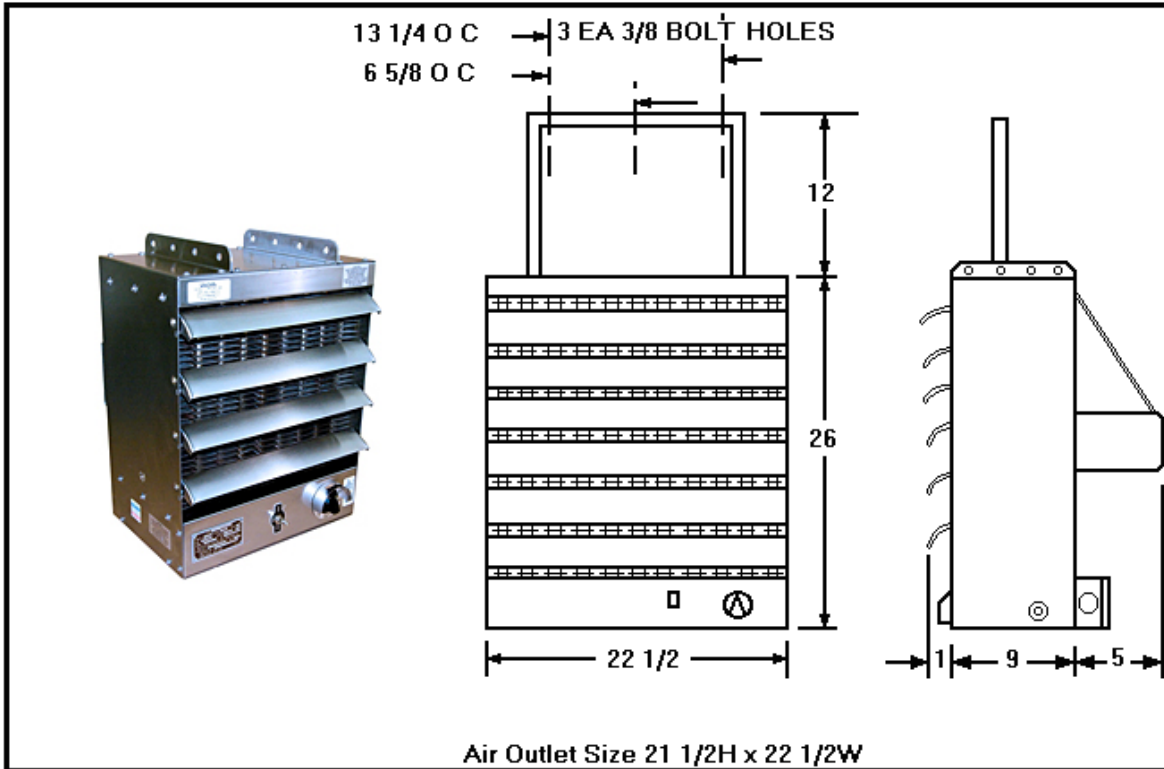

Air Outlet Size 21 1/2H x 22 1/2W

HOW TO ORDER:

212 4 25.0 - 3 - NM

HEATER INCLUDES:

Basic Model
Voltage 440
Wattage 25.0KW
Phase (3)
Stainless Steel (NM)

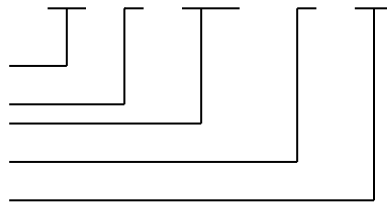

- Operating thermostat (40-100 deg F)
- Auto and Manual Hi-limit Thermostat
- Fused Transformer (when required)
- Contactor
- 12 in. ceiling/bulkhead Bracket
- Terminal Box
- Fan, motor, and louvers
- Fan/Off/Heat Switch

Note: When ordering, specify exact measurements needed from the ranges indicated below.

***Remote Thermostat Optional (24VAC)

***Power Disconnect Switch Optional

***24VAC Control Optional (Standard 120VAC)

Heater Range: Voltage 208-600 VAC
 Wattage 20.0 – 25.0 KW
 Phase 3
 Cycle 60Hz
 Weight 150 lbs.

Construction: -14 GA 304 Stainless Steel
 -15 individual heating elements
 -SST Heating Elements
 -Fins furnace brazed to sheath
 -Heating Elements Hermetically Sealed
 ***Sway Bar Optional
 ***Heater listed to UL-2021 (ETL)

Unit is manufactured I/A/W US Coast Guard, IEEE 45 and ETL/ANSI/UL-2021 specifications.



www.ValadElectric.com

Phone: (888)509-4927

Email: info@valadelectric.com